

EVERGREEN | 3 layouts

Optional Featured Techniques: Embellishing with Distress Oxide™ Ink and Gloss Spray

Project 1



Project 2



Project 3



Materials Needed:

- G1293 Evergreen Scrapbooking Workshop Kit
- Z8014 Speckled Egg Distress Oxide™ Ink Pad (optional)
- Z8015 Rustic Wilderness Distress Oxide™ Ink Pad (optional)
- Z5010 White Gloss Spray(optional)
- Z4572 Blending Brushes (optional)
- Z4575 Black LePen™

- Z1151 3-D Foam Tape
- Paper Trimmer
- Scissors
- Adhesive
- Ruler

Gather photos (14 total)

(P) = portrait (L) = landscape

| | 3 × 3 | 3 × 4 (L) | 3 × 4 (P) | 4 × 6 (L) | 4 × 6 (P) |
|------------------|-------|-----------|-----------|-----------|-----------|
| Project 1 | - | 2 | 2 | - | 1 |
| Project 2 | 3 | - | - | 2 | - |
| Project 3 | 2 | - | - | 1 | 1 |

Getting Started:

- Gather all materials needed.
- Trim all zip strips and set aside. The zip strip is the ½" accent paper along the top of each sheet of patterned paper.
- Check the cut orientation below each cutting guide image. This will show you how to cut the paper, keeping the patterns on your project pieces facing the right direction.
- Light grey pieces on your cutting guide are project pieces. White pieces are leftover paper.
- As you cut the paper, label and sort the pieces as indicated in the cutting guide, creating a stack for each project.

Key:

✂ = first cut | * = use back of paper

Cutting Diagrams:

zip strips

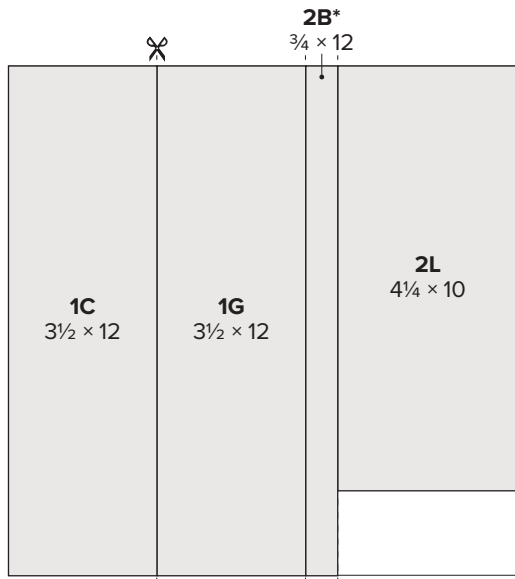
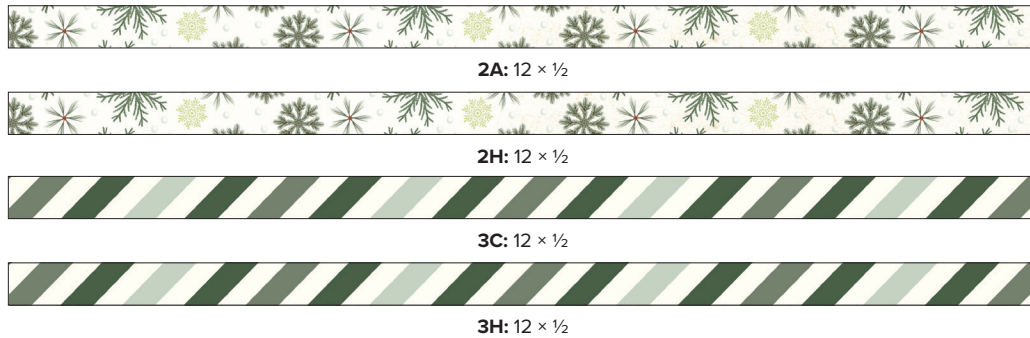

cut orientation



front

*back

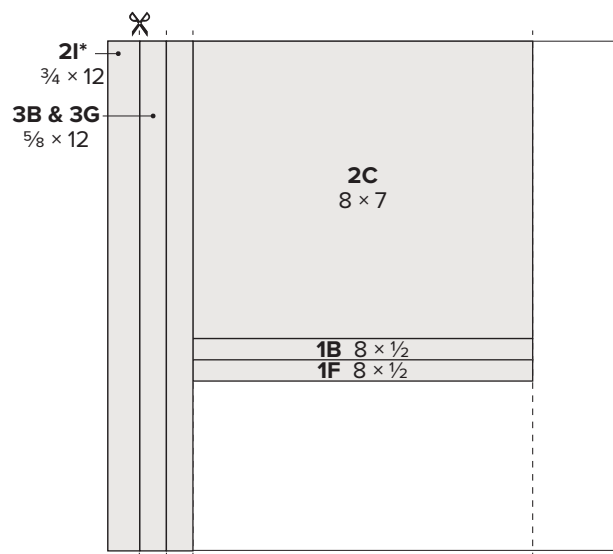

cut orientation

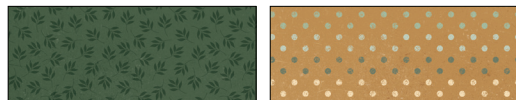

front

*back

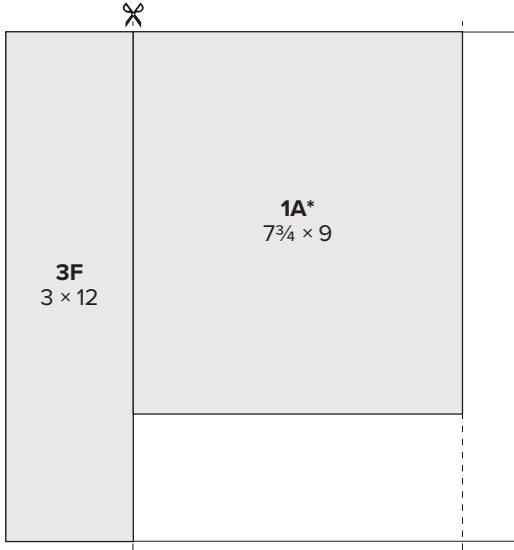

cut orientation



front

*back

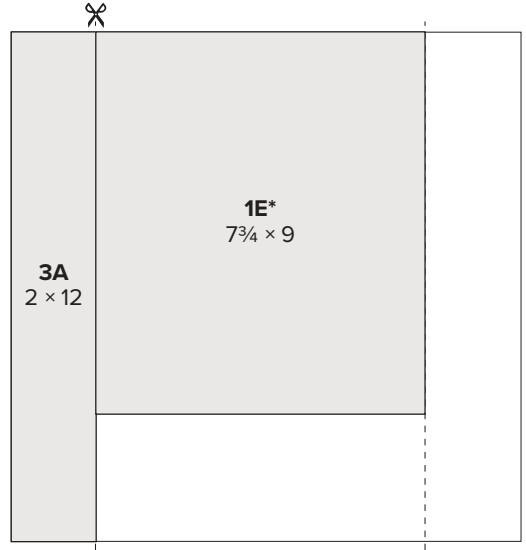

cut orientation



front

*back

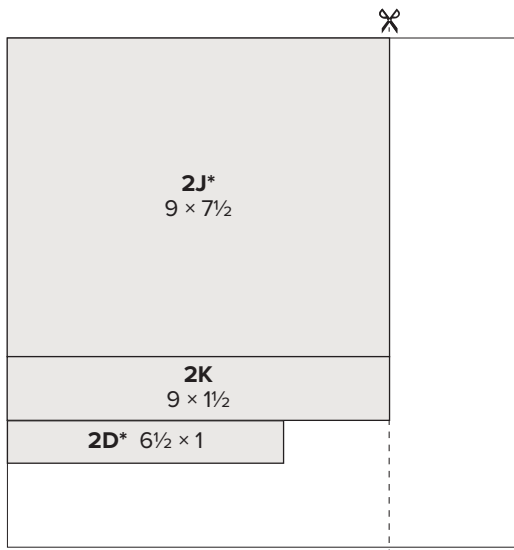

cut orientation

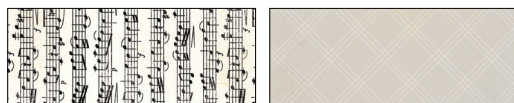

front

*back

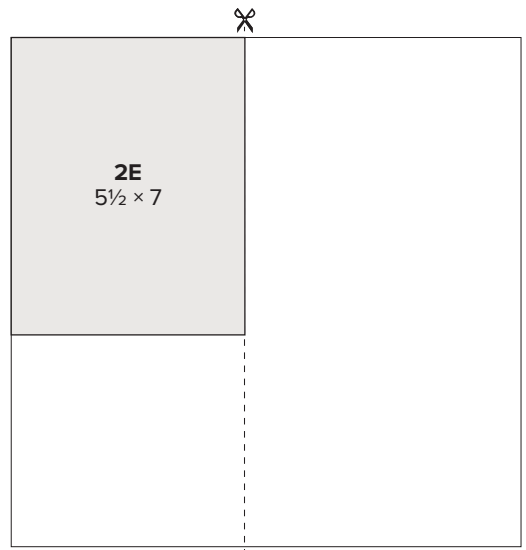

cut orientation



front

*back

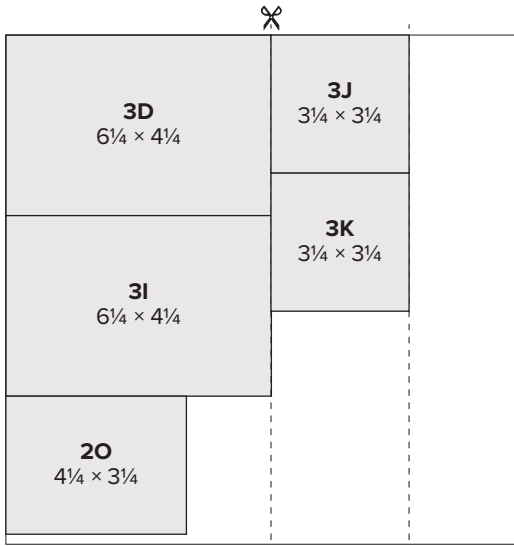

Pine cardstock



dark

*light

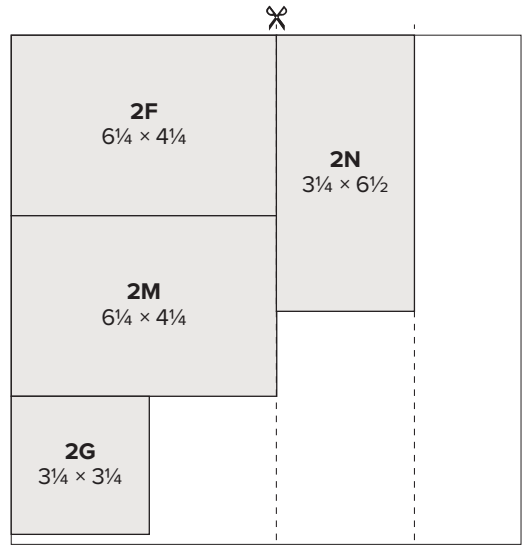

Acorn cardstock

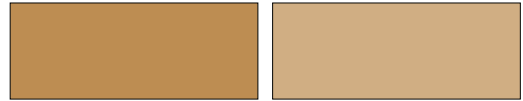

dark

*light

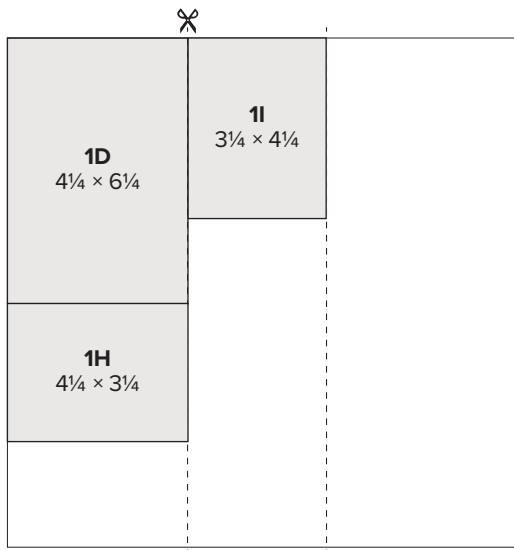

Rosemary cardstock



dark

*light

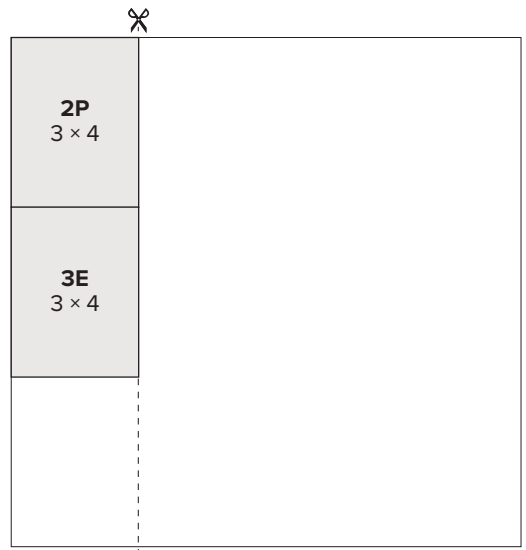

French Vanilla cardstock



Project 1: Left Page



Prepare (for both pages):

- (Optional) Add color to both base pages (exclusive 12" x 12" Sage patterned paper) with Speckled Egg and Rustic Wilderness Distress Oxide™ inks and a blending brush, as shown
Tip: Layer and blend the colors in a few places, applying them one at a time.
Technique: Load the brush with ink by rubbing the bristles on the ink pad. Apply the ink to the paper using a gentle circular motion.
- (Optional) Spray both base pages with white gloss spray, as shown
Tip: Spray the paper from approx. 8 inches away and in an area you don't mind getting messy. Gloss sprays stain.

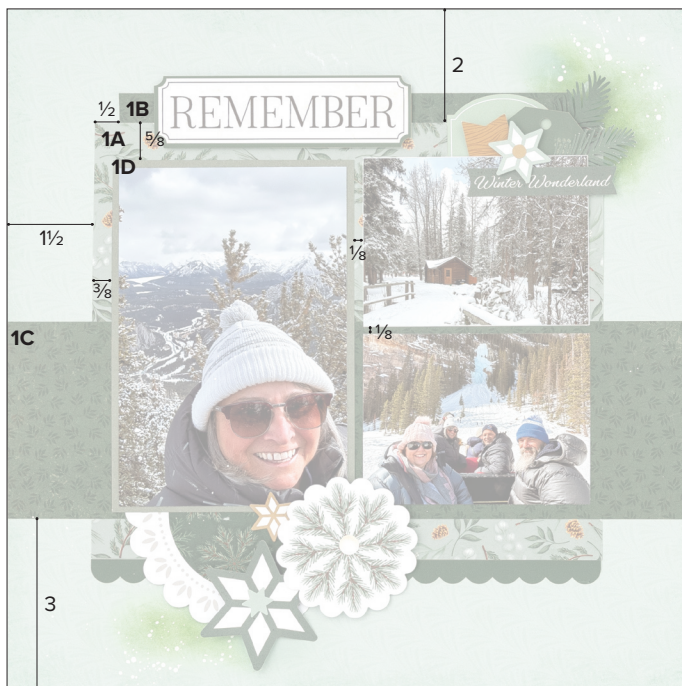

Assemble:

1. Use prepared exclusive Sage patterned paper for base page
2. Attach 1A and 1B
3. Attach 1C
4. Attach 1D
Tip: Do not use adhesive along the bottom so other pieces can be tucked behind it in a later step.
5. Attach photos
Tip: Do not use adhesive along the top of the top right photo so other pieces can be tucked behind it in a later step.
6. Embellish with stickers and die-cuts
Tips: Attach a few of these embellishments with 3-D foam tape for added dimension. Tuck a few die-cuts behind 1D and the top right photo.

Project 1: Right Page

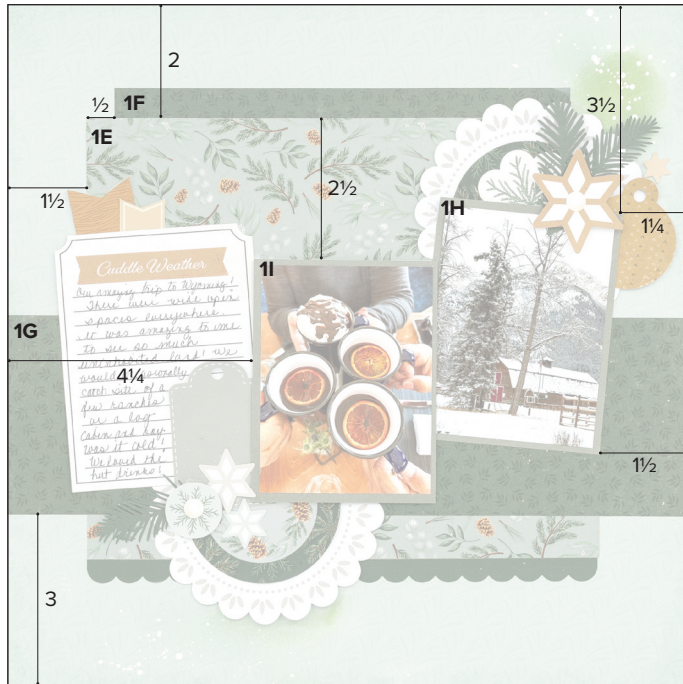

Assemble:

1. Use prepared exclusive Sage patterned paper for base page
2. Attach 1E and 1F
3. Attach 1G
4. Attach 1H
Tip: Do not use adhesive along the top third so other pieces can be tucked behind it in a later step.
5. Attach 1I with 3-D foam tape
Tip: Do not use adhesive along the bottom or the left edge so other pieces can be tucked behind it in a later step.
6. Attach photos
7. Embellish with stickers and die-cuts
Tips: Attach a few of these embellishments with 3-D foam tape for added dimension. Tuck a few stickers and die-cuts behind 1H and 1I.
8. Add journaling

Project 2: Left Page



Prepare (for both pages):

- (Optional) Spray both base pages (exclusive 12" × 12" Mink patterned paper) with white gloss spray, as shown
Tip: Spray the paper from approx. 8 inches away and in an area you don't mind getting messy. Gloss sprays stain.
- (Optional) Color title sticker and two French Vanilla die cut hearts with Speckled Egg Distress Oxide™ ink and a blending brush, as shown
Technique: Load the brush with ink by rubbing the bristles on the ink pad. Apply the ink to the embellishments using a gentle circular motion.

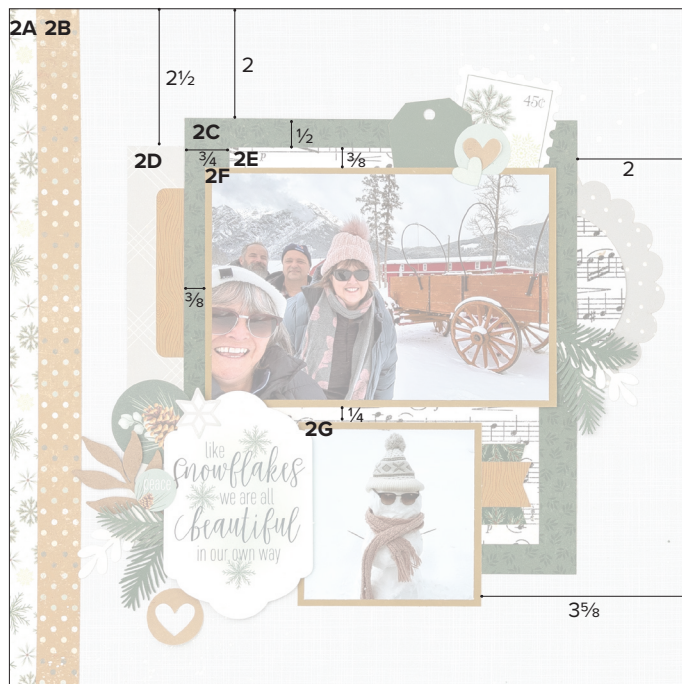

Assemble:

1. Use prepared exclusive Mink patterned paper for base page
2. Attach 2A and 2B
3. Attach 2C and 2D
Tip: Do not use adhesive along the right edge of 2C so other pieces can be tucked behind it in a later step.
4. Attach 2E
5. Attach 2F
Tip: Do not use adhesive along the top right or bottom right edge so other pieces can be tucked behind it in a later step.
6. Attach 2G
Tip: Do not use adhesive along the right edge so other pieces can be tucked behind it in a later step.
7. Embellish with stickers and die-cuts, including prepared title sticker and one prepared heart die-cut
Tips: Attach a few of these embellishments with 3-D foam tape for added dimension. Tuck a few stickers and die-cuts behind 2C, 2F, and 2G.

Project 2: Right Page



Assemble:

1. Use prepared exclusive Mink patterned paper for base page
2. Attach 2H and 2I
3. Attach 2J and 2K
4. Attach 2L
5. Attach 2M with 3-D foam tape
Tips: Do not use adhesive along the top or bottom right edge so other pieces can be tucked behind it in a later step.
6. Attach 2N
Tip: Do not use adhesive along the top right edge or the bottom so other pieces can be tucked behind it in a later step.
7. Attach photos
8. Attach 2O and 2P
Tip: Do not use adhesive along the top of 2O so other pieces can be tucked behind it in a later step.
9. Embellish 2P with frame sticker
10. Embellish with additional stickers and die-cuts, including second prepared heart die-cut
Tips: Attach a few of these embellishments with 3-D foam tape for added dimension. Trim the Mink scalloped circle die-cut in half. Tuck a few stickers and die-cuts slightly behind 2M, 2N, and 2O.
11. Add journaling

Project 3: Left Page

Prepare (for both pages):



- (Optional) Add color to both base pages (12" × 12" French Vanilla cardstock) with Rustic Wilderness and Speckled Egg Distress Oxide™ inks and a blending brush, as shown
Technique: Load the brush with ink by rubbing the bristles on the ink pad. Apply the ink to the cardstock using a gentle circular motion.
- (Optional) Add color to a French Vanilla heart die cut with Speckled Egg Distress Oxide™ ink and a blending brush, as shown

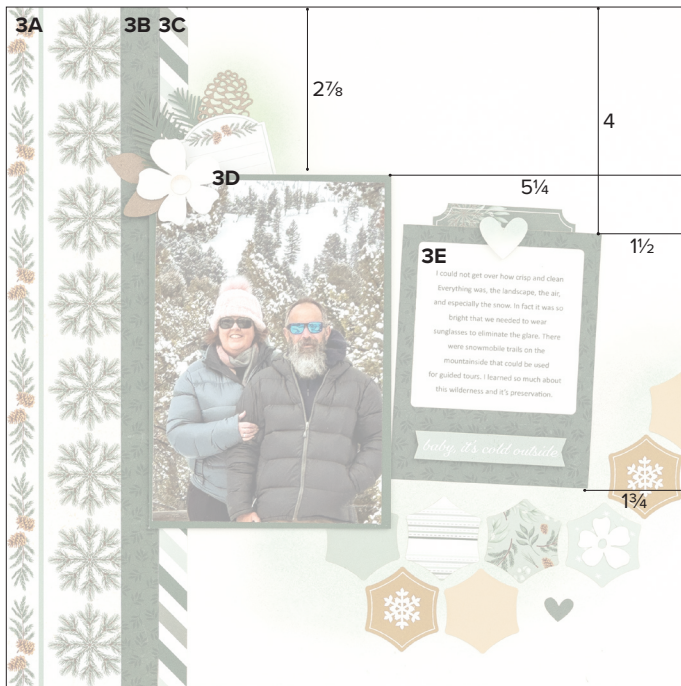

Assemble:

1. Use prepared French Vanilla cardstock for base page
2. Attach 3A, 3B, and 3C
3. Attach 3D with 3-D foam tape
Tips: Do not use adhesive along the top left or bottom right corners so other pieces can be tucked behind them in a later step.
4. Attach Pine frame die-cut to 3E, then attach
Tip: Do not use adhesive along the top of the frame die-cut so another piece can be tucked behind it in a later step.
5. Embellish with stickers and die-cuts, including prepared heart die-cut
Tip: Attach a few of these embellishments with 3-D foam tape for added dimension.

Project 3: Right Page

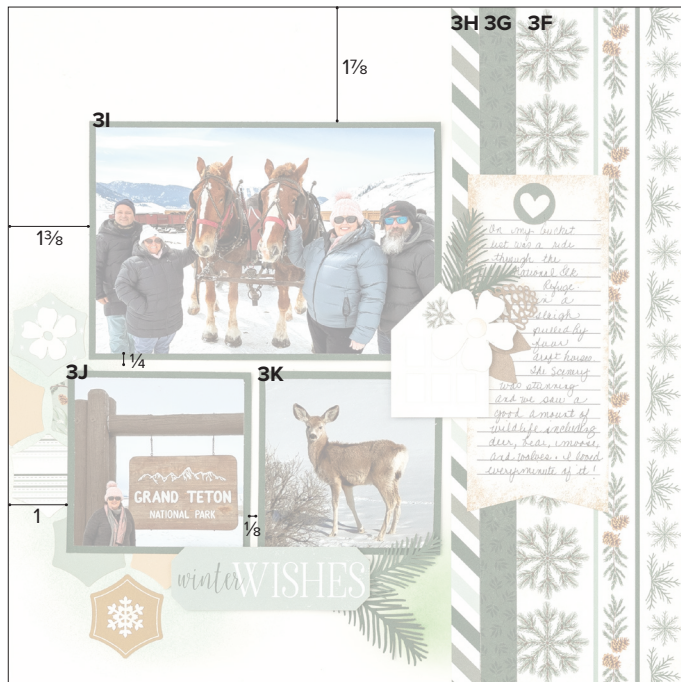

Assemble:

1. Use prepared French Vanilla cardstock for base page
2. Attach 3F, 3G, and 3H
3. Attach 3I, 3J, and 3K
Tip: Only use adhesive along the top right corner of 3J so other pieces can be tucked behind it in a later step.
4. Attach photos
5. Embellish with stickers and die-cuts
Tips: Attach a few of these embellishments with 3-D foam tape for added dimension. Tuck a few of the hex-shaped die-cuts behind 3J.
6. Finish attaching 3J
7. Add journaling