

CAPE COD | 16 cards, 4 each of 4 designs

Featured Technique: Splattering and Painting with Ink

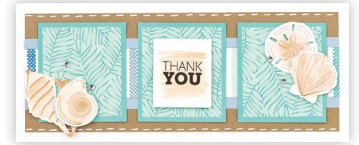

Materials Needed:

- G1284 Cape Cod Cardmaking Workshop Kit
- Z2895 Lagoon Exclusive Inks™ Stamp Pad
- Z6537 Periwinkle Exclusive Inks™ Stamp Pad
- Z2828 Toffee Exclusive Inks™ Stamp Pad
- Z3271 Archival Black Exclusive Inks™ Stamp Pad or
Z2805 Black Exclusive Inks™ Stamp Pad or
Z4189 Intense Black Exclusive Inks™ Stamp Pad
- Z1513 White Gel Pens
- Z3224 Small Round Waterbrush

- Z1151 3-D Foam Tape
- Z5038 Die-cutting & Embossing Machine
- Y1016 1" x 1½" My Acrylix® Block
- Y1002 1" x 3½" My Acrylix® Block
- Y1003 2" x 2" My Acrylix® Block
- Paper Trimmer
- Scissors
- Adhesive
- Ruler

Exclusive Stamp + Thin Cuts:



Just a little
HELLO
from me!

**THANK
YOU**

you're so
SPE-SHELL

let's shell-ebrate!



Getting Started:

- Gather all materials needed.
- Trim all zip strips and set aside. The zip strip is the 1/2" accent paper along the top of each sheet of patterned paper.
- Check the cut orientation below each cutting guide image. This will show you how to cut the paper, keeping the patterns on your project pieces facing the right direction.
- Light grey pieces on your cutting guide are project pieces. White pieces, not including labeled project pieces that must be die cut, are leftover paper.
- As you cut the paper, label and sort the pieces as indicated in the cutting guide, creating a stack for each project.
- If there is a fold line present in a cutting diagram, cut the paper first before folding it. In order to die-cut two shapes at once, place the die on top of the folded paper or stack two paper pieces before running the paper through your die-cutting machine. Paper pieces that can be stacked for die-cutting will be labeled, "stack."

Key:

- ✂ = first cut | * = use back of paper | P = Project
 cut diagonal = angle in trimmer
 - - - - = cut line
 •••••• = fold line
 ■ = suggested Thin Cuts arrangement

Cutting Diagrams:

zip strips



2E: 2 x 1/2 (cut 4)

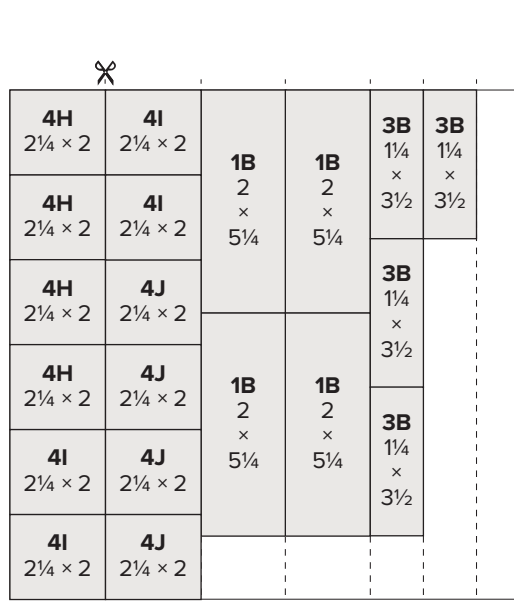

cut orientation



front

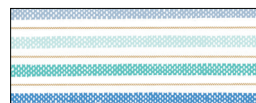

*back

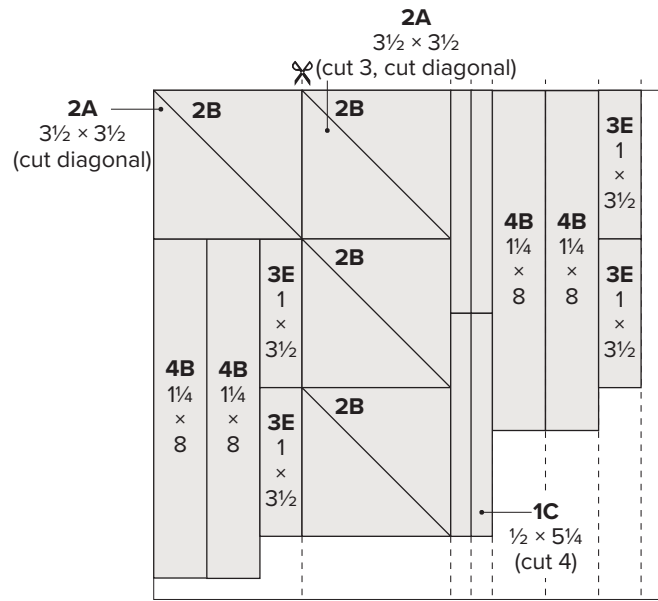

cut orientation

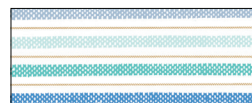

front



*back

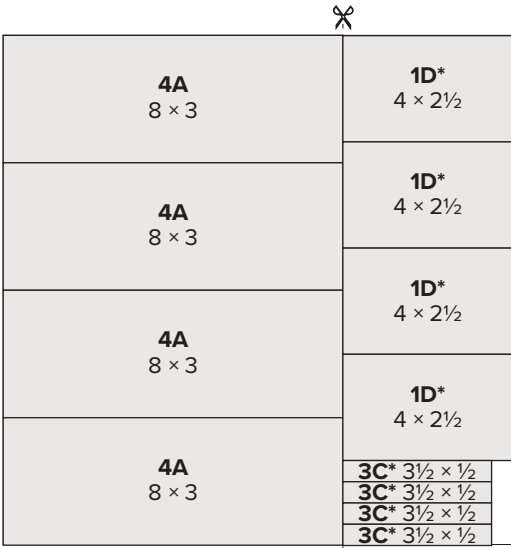

Toffee cardstock

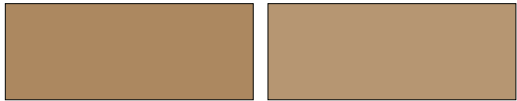

dark

*light

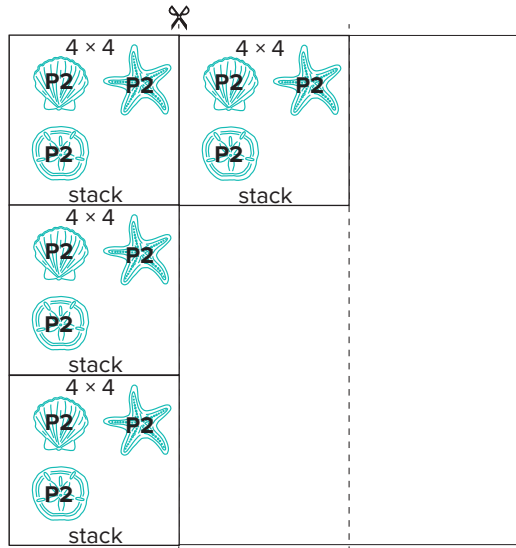

Toffee cardstock

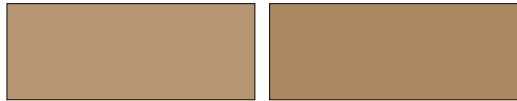

light

*dark

Tip: See the Getting Started section on page two for additional information on how to make two die-cuts at once.

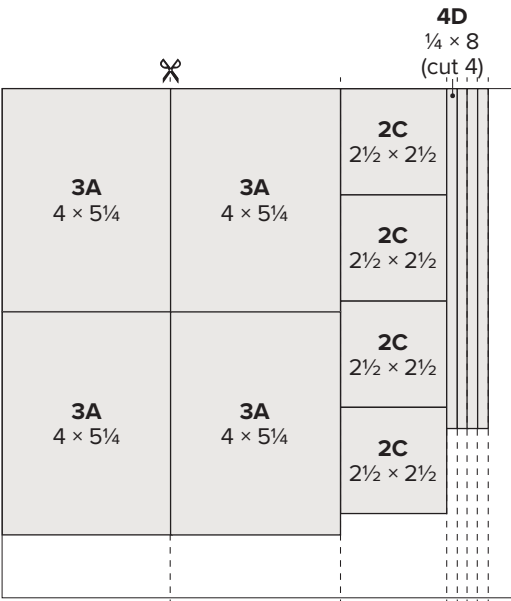

Periwinkle cardstock

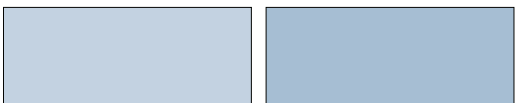

light

*dark

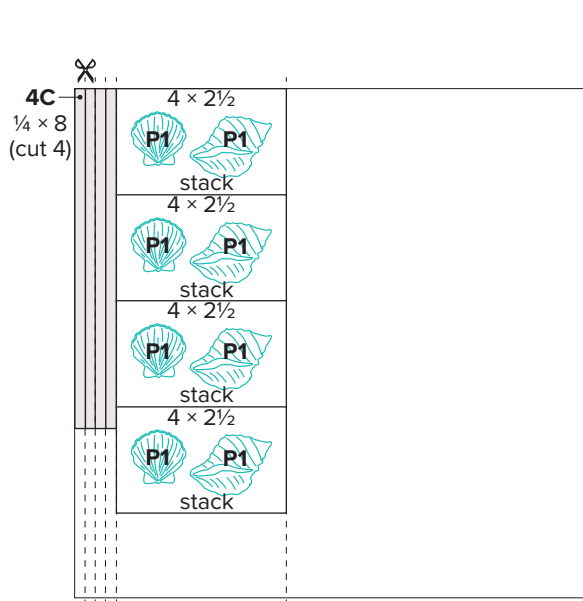

Periwinkle cardstock



light

*dark

Tip: See the Getting Started section on page two for additional information on how to make two die-cuts at once.

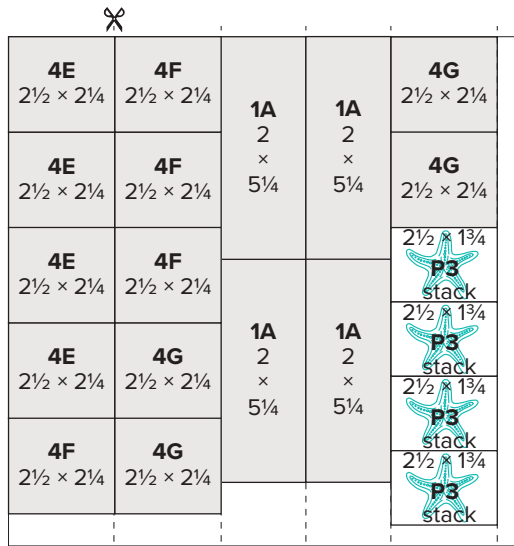

Lagoon cardstock

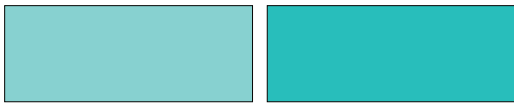

light

*dark

Tip: See the Getting Started section on page two for additional information on how to make two die-cuts at once.

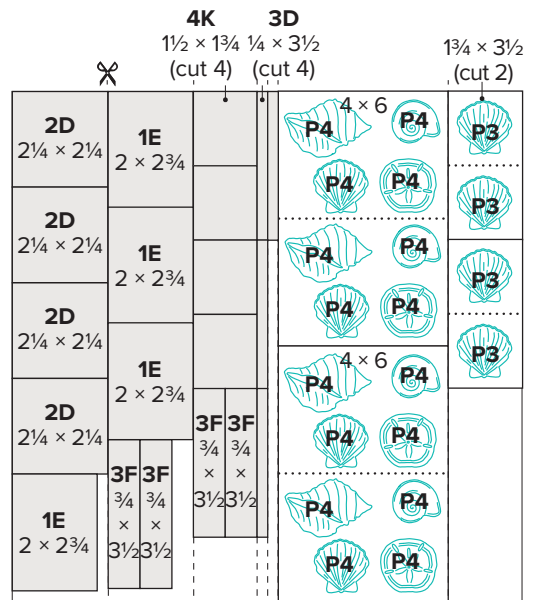

White Daisy cardstock



Tip: See the Getting Started section on page two for additional information on how to make two die-cuts at once.

Project 1: Make 4

Prepare (4 each):



1D:
 Paper: light Toffee
 Ink: Toffee
 Tip: Tear approx. 1/2" off the bottom.



1E:
 Paper: White Daisy
 Inks: Black, Lagoon, Toffee
 Tips: Use the second-generation stamping technique for the leaves. Then, splatter Toffee ink with a waterbrush.
 Techniques: Ink the leaf stamp in Lagoon and stamp it on a scratch piece of paper. Then, without re-inking, stamp on 1E.

Squeeze the closed Toffee stamp pad in the center to transfer some ink to the inside lid. Open the pad and, using the lid as a tray, add a drop of water to the ink with a waterbrush. Pick up ink from this small puddle with the tip of the brush, and gently tap the barrel of the brush on your index finger, above where you want the splatters to land.



P1 Accents:
 Paper: light Periwinkle
 Ink: Toffee
 Tip: Use the stamp pad painting technique.
 Technique: Squeeze the closed stamp pad in the center to transfer some ink to the inside lid. Open the pad and use the inked lid as a tray to paint from.

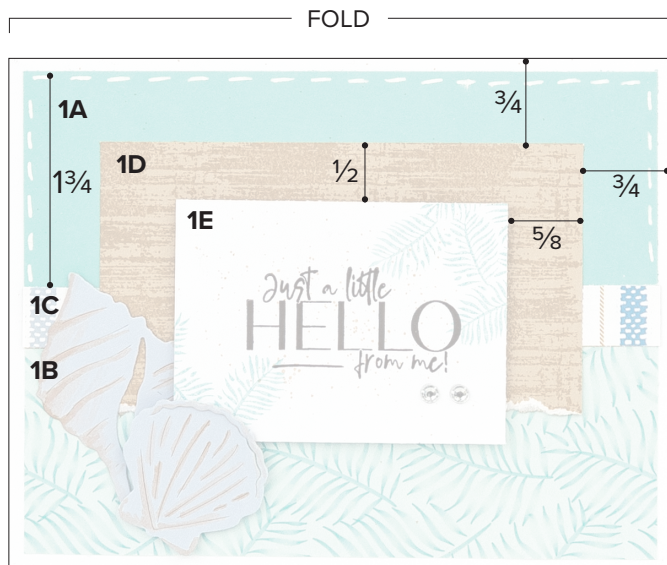

Assemble:

1. Prepare pieces shown above
2. Attach 1A and 1B
3. Attach 1C
4. Attach prepared 1D
5. Attach prepared 1E with 3-D foam tape
Tip: Do not use adhesive along the bottom left corner so another piece can be tucked behind it in a later step.
6. Attach prepared accents, as shown
Tips: Tuck the conch shell slightly behind 1E. Attach the clam shell with 3-D foam tape.
7. Draw dashed border on 1A with white gel pen (.10), as shown
8. Embellish with sparkles

Project 2: Make 4

Prepare (4 each):



2D:
Paper: White Daisy
Inks: Black, Periwinkle



P2 Accents:
Paper: light Toffee
Ink: Toffee
Tip: Use the stamp pad painting technique.
Technique: Squeeze the closed stamp pad in the center to transfer some ink to the inside lid. Open the pad and use the inked lid as a tray to paint from.

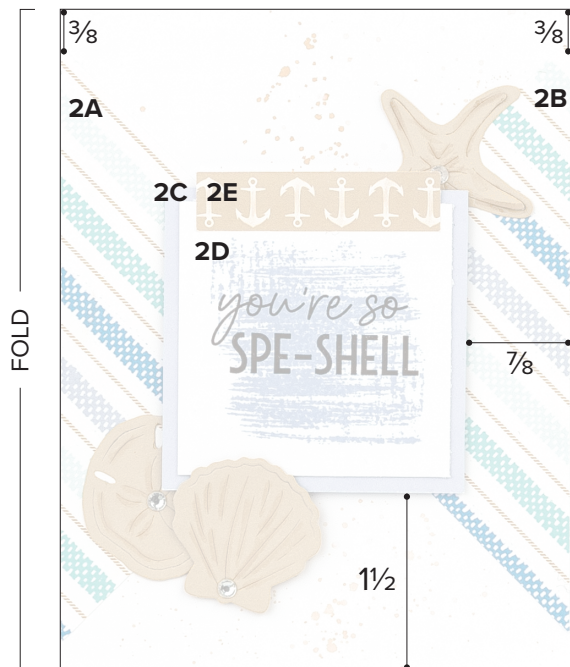

Assemble:

1. Prepare pieces shown above
2. Add splatters to card base with Toffee ink and a waterbrush, as shown
Tip: Squeeze the closed stamp pad in the center to transfer some ink to the inside lid. Open the pad and, using the lid as a tray, add a drop of water to the ink with a waterbrush. Pick up ink from this small puddle with the tip of the brush, and gently tap the barrel of the brush on your index finger, above where you want the splatters to land.
3. Attach 2A and 2B
4. Attach 2C with 3-D foam tape
Tip: Do not use adhesive along the top right and bottom left corners, so other pieces can be tucked behind them in a later step.
5. Attach prepared 2D
6. Attach prepared accents, as shown
Tip: Tuck the starfish and sand dollar accents slightly behind 2C. Attach the clam shell accent with 3-D foam tape.
7. Attach 2E, as shown
8. Embellish with sparkles

Project 3: Make 4

Prepare (4 each):



3A:
Paper: light Periwinkle
Ink: Periwinkle



3C:
Paper: light Toffee
Ink: Black
Tip: Draw a dashed line with the white gel pen (10).



3F:
Paper: White Daisy
Ink: Lagoon



P3 Accent:
Paper: White Daisy
Ink: Toffee
Tip: Use the stamp pad painting technique.
Technique: Squeeze the closed stamp pad in the center to transfer some ink to the inside lid. Open the pad and use the inked lid as a tray to paint from.



Assemble:

1. Prepare pieces shown above
2. Attach 3A
3. Attach 3B, prepared 3C, 3D, 3E, and prepared 3F
4. Attach prepared accents, as shown
Tip: Attach the clam shell accent with 3-D foam tape.
5. Embellish with sparkles

Project 4: Make 4

Prepare (4 each):



4K:

Paper: White Daisy
Inks: Black, Toffee

Tip: Use the stamp pad painting technique for the background.

Technique: Squeeze the closed stamp pad in the center to transfer some ink to the inside lid. Open the pad and use the inked lid as a tray to paint from.



P4 Accents:

Paper: White Daisy
Ink: Toffee

Tip: Use the stamp pad painting technique.

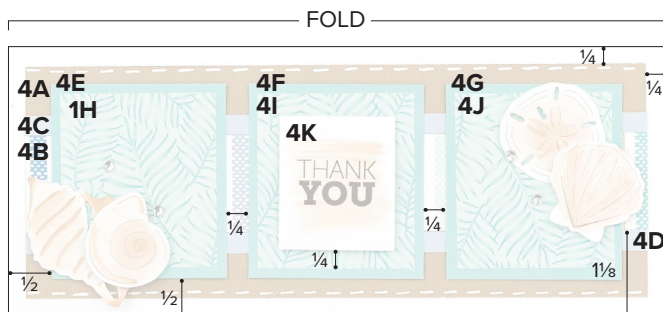

Assemble:

1. Prepare pieces shown above
2. Attach 4A
3. Attach 4B, 4C, and 4D
4. Attach 4E, 4F, and 4G
5. Attach 4H, 4I, and 4J, as shown
6. Attach 4K with 3-D foam tape
7. Draw dashed line on 4A with white gel pen (.10)
8. Attach prepared accents, as shown
Tip: Attach a few of these accents with 3-D foam tape.
9. Embellish with sparkles