

# HEY HANDSOME | 16 cards, 4 each of 4 designs

## Featured Technique: Distressing with Sandpaper



### Materials Needed:

- G1279 Hey Handsome Cardmaking Workshop Kit
- Z6533 Harbour Exclusive Inks™ Stamp Pad
- Z6540 Pine Exclusive Inks™ Stamp Pad
- Z2828 Toffee Exclusive Inks™ Stamp Pad
- Z3271 Archival Black Exclusive Inks™ Stamp Pad  
or Z4189 Intense Black Exclusive Inks™ Stamp Pad  
or Z2805 Black Exclusive Inks™ Stamp Pad
- Z1151 3-D Foam Tape
- Z5038 Die-cutting & Embossing Machine

- Y1000 1" x 1" My Acrylix® Block
- Y1016 1" x 1½" My Acrylix® Block
- Y1002 1" x 3½" My Acrylix® Block
- Y1003 2" x 2" My Acrylix® Block
- Paper Trimmer
- Scissors
- Adhesive
- Ruler
- Fine Grit Sandpaper

### Exclusive Stamp + Thin Cuts:

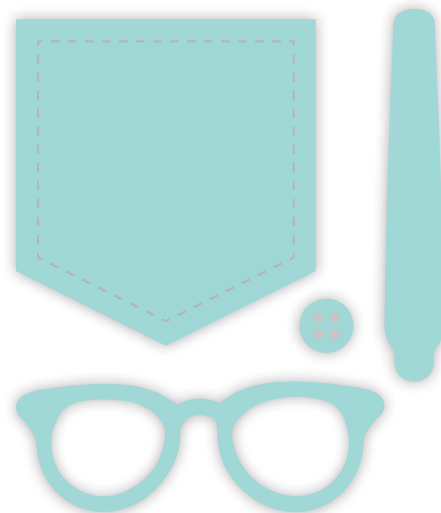

## Getting Started:

- Gather all materials needed.
- Trim all zip strips and set aside. The zip strip is the 1/2" accent paper along the top of each sheet of patterned paper.
- Check the cut orientation below each cutting guide image. This will show you how to cut the paper, keeping the patterns on your project pieces facing the right direction.
- Light grey pieces on your cutting guide are project pieces. White pieces, not including labeled project pieces that must be die cut, are leftover paper.
- As you cut the paper, label and sort the pieces as indicated in the cutting guide, creating a stack for each project.
- If there is a fold line present in a cutting diagram, cut the paper first before folding it. In order to die-cut two shapes at once, place the die on top of the folded paper or stack two paper pieces before running the paper through your die-cutting machine. Paper pieces that can be stacked for die-cutting will be labeled, "stack."

## Key:

✂ = first cut | \* = use back of paper | P = Project

- - - - = cut line

■ = suggested Thin Cuts arrangement

## Cutting Diagrams:

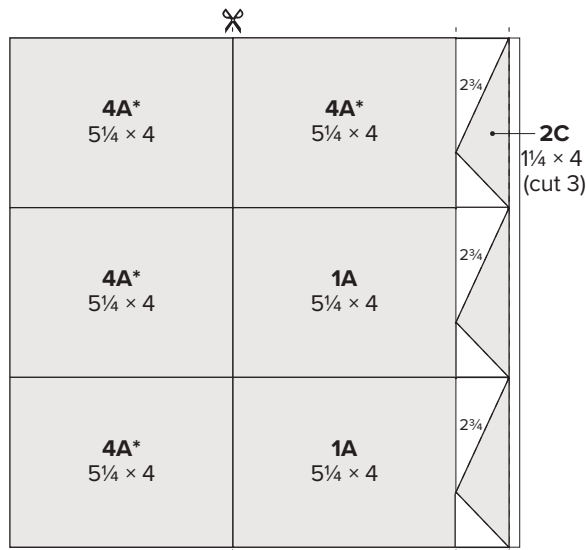

cut orientation

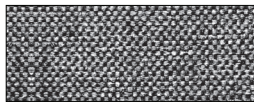

front



\*back

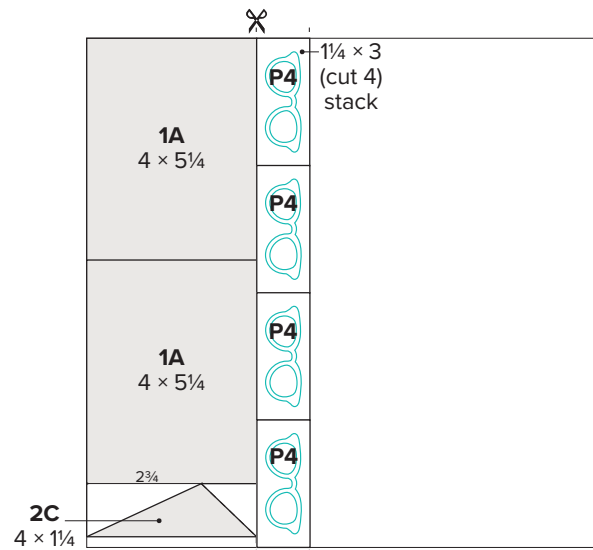

cut orientation

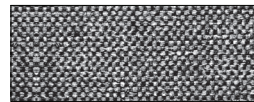

front



\*back

*Tip: See the Getting Started section above for additional information on how to make two die-cuts at once.*

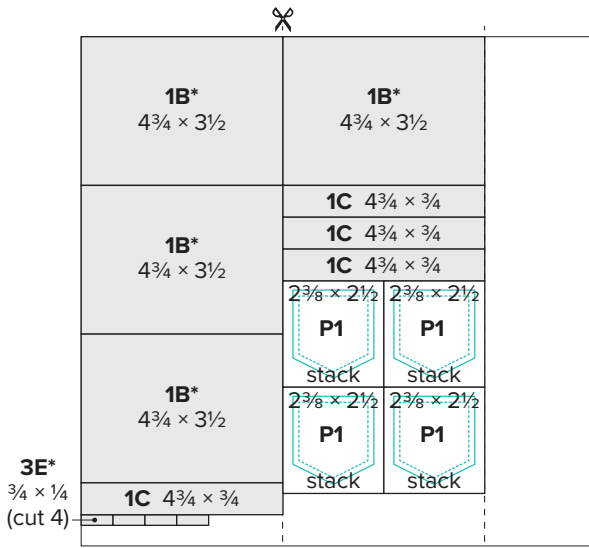

Paprika cardstock

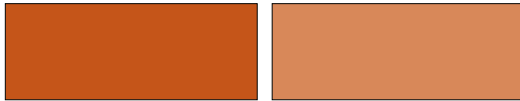

dark

\*light

Tip: See the Getting Started section on page two for additional information on how to make two die-cuts at once.

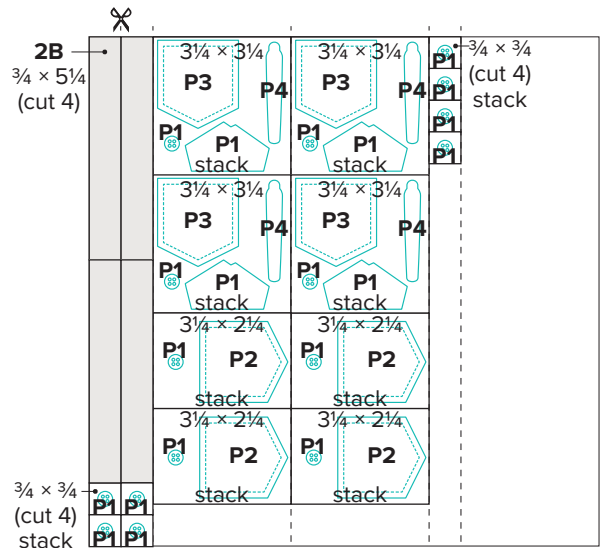

Mink cardstock



light

\*dark

Tip: See the Getting Started section on page two for additional information on how to make two die-cuts at once.

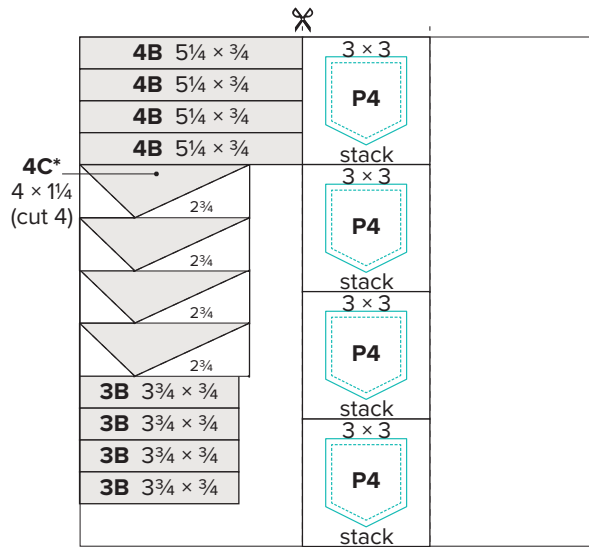

Toffee cardstock

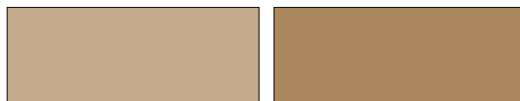

light

\*dark

Tip: See the Getting Started section on page two for additional information on how to make two die-cuts at once.

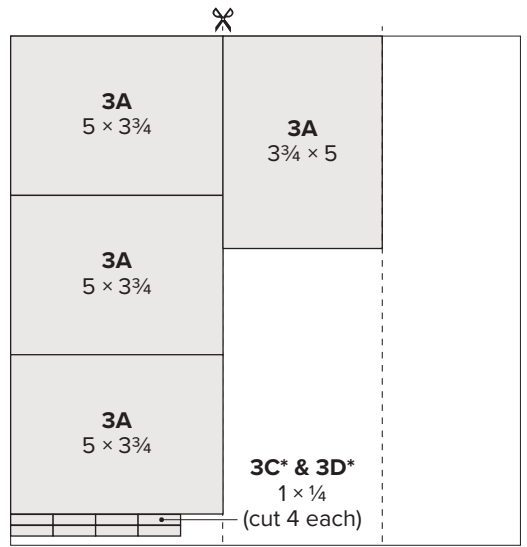

Harbour cardstock



light

\*dark

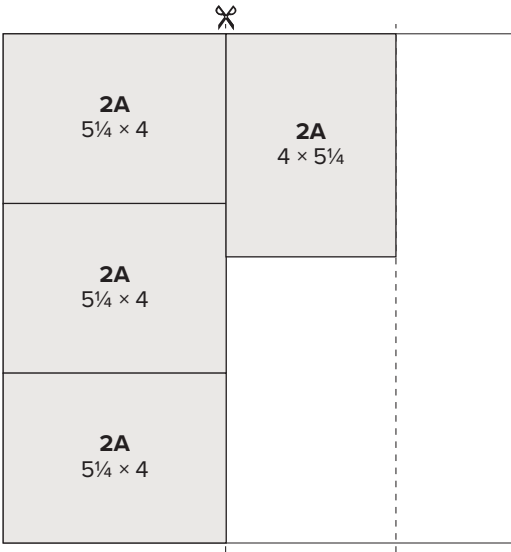

*Pine cardstock*



*light*



*\*dark*

**Project 1: Make 4**

**Prepare (4 each):**

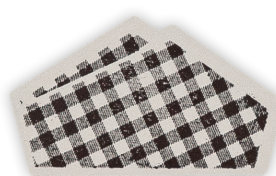

**P1 Accent:**  
Paper: light Mink  
Ink: Black



**P1 Accent:**  
Paper: Paprika  
Ink: Black

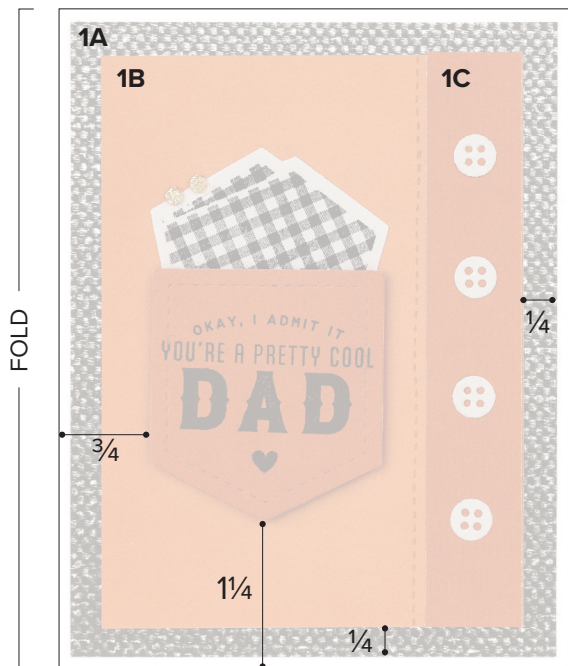

**Assemble:**

1. Prepare pieces shown above
2. Attach 1A
3. Attach 1C on top of 1B
4. Stamp stitched lines on 1B with Toffee ink, as shown
5. Attach prepared 1B
6. Attach prepared pocket accent with 3-D foam tape
7. Attach prepared pocket square, as shown
8. Attach P1 light Mink cardstock buttons, as shown
9. Embellish with gems

**Project 2: Make 4**

**Prepare (4 each):**



**2A:**  
Paper: light Pine  
Ink: Pine



**2B:**  
Paper: light Mink  
Ink: Black, Harbour



**P2 Accent:**  
Paper: light Mink  
Ink: Black



**Assemble:**

1. Prepare pieces shown above
2. Attach prepared 2A
3. Attach prepared 2B on top of 2A
4. Attach 2C
5. Attach prepared pocket accent with 3-D foam tape
6. Embellish with gems

**Project 3: Make 4**

**Prepare (4 each):**



**3A:**  
 Paper: light Harbour  
 Tip: Distress with sandpaper to create a denim-like look.  
 Technique: Rub the sandpaper in one direction, first, across the whole of 3A. Then, rub the sandpaper in a perpendicular direction to the first.

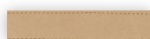

**3B:**  
 Paper: light Toffee  
 Ink: Toffee



**P3 Accent:**  
 Paper: light Mink  
 Inks: Black, Harbour

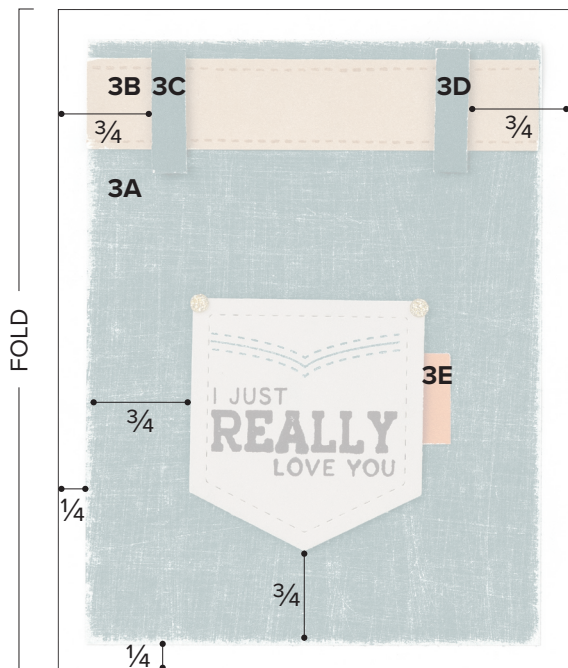

**Assemble:**

1. Prepare pieces shown above
2. Attach prepared 3A
3. Attach prepared 3B
4. Attach 3C and 3D with 3-D foam tape
5. Attach prepared pocket accent with 3-D foam tape
6. Attach 3E, as shown
7. Embellish with gems

Project 4: Make 4

Prepare (4 each):



**4B:**  
Paper: light Toffee  
Inks: Black, Toffee

**4C:**  
Paper: Toffee  
Ink: Black

**P4 Accent:**  
Paper: light Toffee  
Ink: Black

**P4 Accent:**  
Paper: light Mink  
Ink: Black



Assemble:

1. Prepare pieces shown above
2. Attach 4A
3. Attach prepared 4B on top of 4A
4. Attach prepared 4C
5. Attach prepared pocket accent with 3-D foam tape  
*Tip: Do not use adhesive along the top so another accent can be tucked behind it in a later step.*
6. Attach prepared pen accent, as shown  
*Tip: Tuck slightly behind pocket.*
7. Attach P4 glasses accent, as shown  
*Tip: Attach corners with 3-D foam tape.*
8. Embellish with gems